

R302MLP/ A

SQUARE-FIELD, X-RAY COLLIMATOR SUITABLE FOR INSTALLATION ON STATIONARY X-RAY EQUIPMENT. MOUNTING PLANE AT 80 MM (3.14") FROM THE FOCUS.

The x-ray field is defined by 6 pairs of shutters, four of which are lead-lined. The six pairs of shutter move perpendicularly within the x-ray field. Two pairs of bronze shutters are located near the focus, two are located near the entrance window and two are located near the exit window of the x-ray beam from the collimator. The latter shutters serve to accurately define the x-ray field edges.

Shutter movements are motorised: shutter positioning is potentiometer controlled and adjusted remotely or by two knobs on the collimator front panel.

The square-field X-ray beam Limiting Device is designed for installation on rotating or fixed anode X-ray tubes (EN 60601-1-3 par 29.202.3); motorised controls provide for the adjustment of the X-ray field dimension to the size of the image receptor or to that of the anatomical area of interest. Adjustment to the area under investigation is controlled remotely or by two knobs on the collimator front panel.

Direct visualisation of the x-ray field is provided by a light beam which corresponds to the x-ray beam, within a tolerance of two percent of the selected FFD (SID) value. The light-field centre is provided by the intersection of two perpendicular lines silk-screened into the Lexan window and projected on the light field by the light beam.

To activate the light field, press the area marked with the light symbol on the front of the device. The light will switch on for 30 seconds and an electronic timer will switch the lamp OFF automatically.

Average illumination is not less than 160 lux; edge contrast ratio is minimum 4:1. Field size at the different

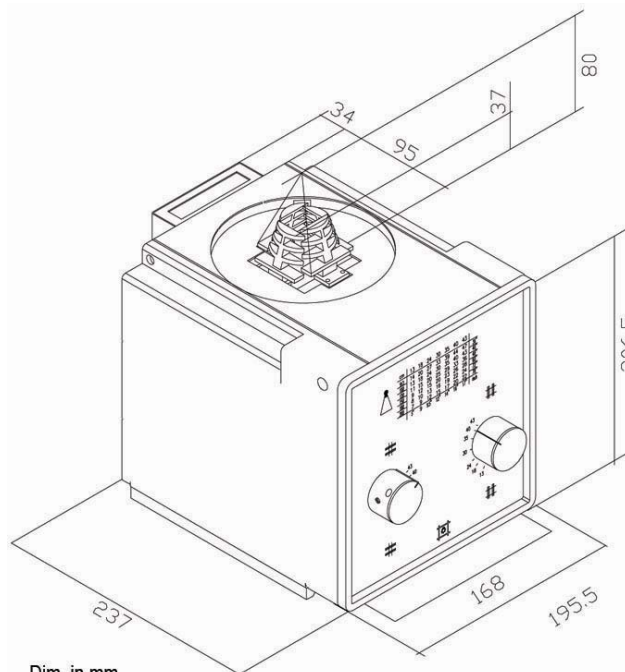

Dim. in mm
9,5kg

Focus Film Distance (FFD - SID) settings is shown on the front panel.

TECHNICAL FEATURES:

- External adjustment of mirror angulation.
- High luminosity provided by a quartz iodide lamp.
- Timer limiting projection lamp exposure time to 30 seconds thus extending lamp life by preventing overheating.
- Radiation shielding: 150 kVp - 4mA
- Minimum inherent filtration 2 mm aluminium equivalent (1 mm on request).
- Continuous film coverage from Min: 00 x 00 cm to Max: 48 x 48 cm at 100 cm FFD (SID).

OPTIONAL ITEMS:

- RO 001 - Mounting flange, leaded, fixed, thickness 20 mm
- RO 002 - Spacers, iron, 1.5mm thickness, for mounting flange
- RO 012/A - Tape measure, retractable with knob.
- RO 023/A - Spacers, x-ray beam/patient
- RO 041 - Mirror, mylar, inh. Filtr 0,3 mm Al equal.
- RO 051 - Mounting flange, rotating, diam 136. thickness 18 mm.
- RO 077 - Potter Bucky light centring device (BL)
- RO 082 - Mirror, 0,8 mm - int. Filtr 1 mm Al equal.
- RO 153/1 - Laser, Potter Bucky centring with power supply.
- RO 161 - Spacers, guide, for ionisation chamber, pair.
- RO 333 - Power Led.

Ralco s.r.l.

RALCO SRL
VIA DEI TIGLI 13/G
20046 BIASSONO ITALIA
TEL. +39 0392497925
FAX. +39 0392497799
www.ralco.it email: ralco@ralco.it